



FERRI

Construction



SIMPLY. **THE MOWER**

Gamma di testate, trinciatrici, e decespugliatrici idrauliche per la manutenzione del verde, per applicazioni a macchine movimento terra.

Range of flail heads, bush cutters and hydraulic reach mowers for maintenance of green areas, for construction equipment applications.



TME



TID



THME



THLD



THM



TIR



TSKID



TST



SIMPLY. THE MOWER



Certified ISO 9001

Oltre 170 anni di storia

Dal 1844 e da sei generazioni, Ferri è sinonimo di innovazione tecnologica. Un'evoluzione ottenuta puntando sempre su ricerca e sviluppo di macchine per la manutenzione del verde pubblico e agricolo.

Oggi la Ferri con una produzione e vendita di oltre 25.000 macchine in tutto il mondo, si colloca tra le aziende leader del settore in Europa.

La sicurezza e la qualità per il nostro futuro

Lo spirito innovativo che ha caratterizzato, da sempre, la progettazione e la produzione dei prodotti della Ferri si è sempre basato su concetti semplici ma efficaci, miglioramento del comfort dell'operatore che significa maggiore sicurezza, fare tesoro dei suggerimenti di chi lavora tutti i giorni con i prodotti Ferri, ricerca costante della migliore qualità sul mercato stringendo collaborazioni strategiche, di lungo termine, con i migliori fornitori nazionali ed internazionali.

Tutto questo in sintesi è alla base dell'ultimo nato in casa Ferri, il **porta-attrezzi radiocomandato iCUT 3**, progettato in collaborazione con studi tecnici all'avanguardia, non solo nel settore agricolo, che ha come obiettivo, offrire una valida alternativa, in totale sicurezza, a chi è chiamato ad operare in condizioni difficilmente praticabili con i mezzi tradizionali.

La stessa linea guida che ha permesso di ottenere nel corso del 2016 il prestigioso marchio di **UnimogPartner by Mercedes-Benz**, grazie allo sviluppo di un modello Ferri dedicato per risolvere specifiche esigenze operative della gamma Unimog.

Ferri, il futuro premia chi crede nel futuro.

Over 170 years of history

Since 1844 and for six generations, Ferri has been synonymous with Technological Innovation. This evolution has been achieved through continuous focus on the research and development of machines for the maintenance of public and agricultural greenery.

Today, Ferri is one of the industry's leading companies in Europe with production and sales of more than 25,000 machines worldwide.











Certainty and quality for our future





The innovative spirit that has always characterised the design and production of Ferri products has always been based on simple yet effective concepts, such as improved operator comfort for greater safety, making the most of suggestions from those who work with Ferri products on a daily basis, consistently seeking the best quality on the market and solidifying long-term strategic partnerships with the best national and international suppliers.

*All of this underpins the latest Ferri product, the **iCUT 3 remote controlled carrier machine**, designed in conjunction with state-of-the-art technical studies, not just in the agricultural sector, which aims to provide a viable and completely safe alternative for those operating in difficult conditions with traditional means.*

*The same guideline has allowed us to attain the prestigious **UnimogPartner by Mercedes-Benz** brand in 2016, thanks to the development of a Ferri model designed for the specific operating needs of the Unimog range.*

Ferri, the future rewards those who believe in the future.

Mod.	min  max		Utensili di taglio / Cutting flails			Pag.
	m	ft				
TME	0,60 - 0,80	1.9 - 2.6		-	-	4
TID	1,00	3.3		-	-	5
THME	0,80	2.6		-	-	6
THLD	0,85 - 1,05	2.8 - 3.4			-	7
THM	1,05 - 1,25	3.4 - 4.1				8
TIR	145	4.7			-	9

Mod.	min  max		min HP max	Utensili di taglio / Cutting flails			Pag.
	m	ft					
TSKID	1,60 - 2,00	5.2 - 7.3	55 ÷ 95			-	10
TST	1,05	3.4	-			-	12



FERRI

SIMPLY. THE MOWER

TMETESTATE TRINCIANTI IDRAULICHE PER MINIESCAVATORI
FLAIL HEADS FOR MINI-EXCAVATORS

1500 ÷ 2000 Kg

3307 ÷ 4410 lb



12 ÷ 24 lt./min

2.63 ÷ 5.27 gal/min



Ø max 2 cm

Ø max 0.79 in

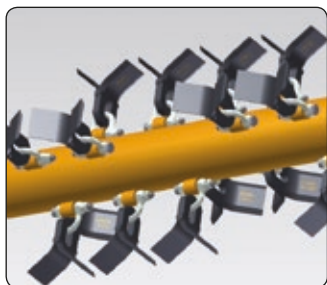
**LIGHT SERIES****Dotazione standard**

- Valvola di massima ed anticavitazione.
- Tubi idraulici con raccorderia protetti da spirale - m 1,50 (esclusi innesti rapidi).
- Trasmissione diretta.
- Rullo di appoggio regolabile in altezza.
- Controtelaio interno.
- Protezioni in gommata antiabrasione.

Accessori

- Kit valvola regolatrice in acciaio tarata completa di tubi collegamento motore per portate fino a 90 litri con prioritaria a 60 litri.
- Attacco a disegno con perni Ø mm 30/35/40.

Standard

- Anti-shock + anti-cavitation valve.
- Hydraulic pipes and connections protected by spiral (m 1,50) (quick couplings excluded).
- Direct drive.
- Rear adjustable roller.
- Double skin flail head.
- Front and rear abrasion resistant guard.

Accessories

- Calibrated steel adjusting valve Kit for capacities up to 90 litres with 60 litres priority valve.
- Linkage as per drawing pins Ø mm 30/35/40.

**INFORMAZIONI TECNICHE - TECHNICAL DATA**

Modello Model										
	m	ft	m	ft	Kg*	lbs*	lt min÷max	Gal min÷max	max bar	max psi
TME60	0,60	1.96	0,79	2.59	70	154	12 ÷ 24	2.63 ÷ 5.27	200	2900
TME80	0,80	2.88	0,99	3.25	88	194	12 ÷ 24	2.63 ÷ 5.27	200	2900

* Attacco escluso - Linkage not included

UTENSILI DA TAGLIO - CUTTING FLAILS

Intercambiabili sullo stesso rotore Interchangeable on the same rotor		TME60	TME80		
		Nr. - No	Nr. - No	Ø cm	Ø in
Coltelli snodati per: erba e cespugli Articulated "Y" flails for: grass, bushes		32	40	2	0,79



2500 ÷ 3500 kg
5511 ÷ 7716 lb



32 ÷ 42 lt/min
7.04 ÷ 9.23 gal/min



Ø max 2 cm
Ø max 0.79 in



Construction

TESTATE TRINCIANTI IDRAULICHE PER MINIESCAVATORI
FLAIL HEADS FOR MINI-EXCAVATORS

LIGHT SERIES

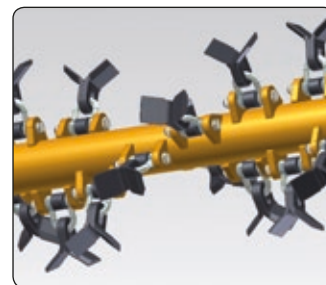

Dotazione standard

- Valvola di massima ed anticavitazione.
- Tubi idraulici con raccorderia protetti da spirale - m 1,50 (esclusi innesti rapidi).
- Trasmissione diretta.
- Rullo di appoggio regolabile in altezza.
- Controtelaio interno.
- Protezioni in gommata antiabrasione.

Accessori

- Kit valvola regolatrice in acciaio tarata completa di tubi collegamento motore per portate fino a 90 litri con prioritaria a 60 litri.
- Attacco a disegno con perni Ø mm 30/35/40.

Standard

- Anti-shock + anti-cavitation valve.
- Hydraulic pipes and connections protected by spiral - m 1,50 (quick couplings excluded).
- Direct drive.
- Rear adjustable roller.
- Double skin flail head.
- Front and rear abrasion resistant guard.

Accessories

- Calibrated steel adjusting valve Kit for capacities up to 90 litres with 60 litres priority valve.
- Linkage as per drawing pins Ø mm 30/35/40.

INFORMAZIONI TECNICHE - TECHNICAL DATA

Modello Model										
	m	ft	m	ft	Kg*	lbs*	lt min÷max	Gal min÷max	max bar	max psi
TID 100	1,00	3.28	1,20	3.94	129	284	32÷42	7.04 ÷ 9.23	200	2900

* Attacco escluso - Linkage not included

UTENSILI DA TAGLIO - CUTTING FLAILS

Intercambiabili sullo stesso rotore Interchangeable on the same rotor		TID 100		
		Nr. - No	Ø cm	Ø in
Coltelli snodati per: erba e cespugli Articulated "Y" flails for: grass, bushes		36	2	0,79

FERRI[®]

SIMPLY. THE MOWER

THME

1500 ÷ 3000 Kg

3307 ÷ 6614 lb



12 ÷ 32 lt./min

2.64 ÷ 7.04 gal/min



Ø max 2 cm

Ø max 0.79 in

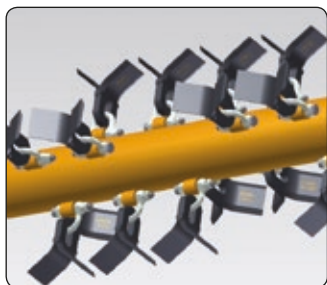
**TESTATE TRINCIANTI IDRAULICHE PER MINIESCAVATORI**
FLAIL HEADS FOR MINI-EXCAVATORS**Dotazione standard**

- Dispositivo autolivellante (escludibile meccanicamente).
- Telaio con rinforzi interni ed esterni.
- Valvola di massima ed anticavitazione.
- Tubi idraulici con raccorderia protetti da spirale - m 1,50 (esclusi innesti rapidi).
- Trasmissione diretta.
- Rullo di appoggio regolabile in altezza.
- Pattini antiusura sostituibili.
- Controtelaio interno.
- Protezioni in gommata antiabrasione.

Accessori

- Kit valvola regolatrice in acciaio tarata completa di tubi collegamento motore per portate fino a 90 litri con prioritaria a 60 litri.
- Attacco a disegno con perni Ø mm 30/35/40.

Standard

- Self-levelling device (with mechanical lock).
- Frame with internal and external reinforcements
- Anti-shock + anti-cavitation valve.
- Hydraulic pipes and connections protected by spiral - m 1,50 (quick couplings excluded).
- Direct drive.
- Rear adjustable roller.
- Replaceable wear skids.
- Double skin flail head.
- Front and rear abrasion resistant guard.

Accessories

- Calibrated steel adjusting valve Kit complete with pipes for capacities up to 90 liters with 60 liters priority valve.
- Linkage as per drawing pins Ø mm 30/35/40.

**INFORMAZIONI TECNICHE - TECHNICAL DATA**

Modello Model										
	m	ft	m	ft	Kg*	lbs*	lt min÷max	Gal min÷max	max bar	max psi
THME 60	0,60	1.97	0,79	2.59	110	242	12÷24	2.64 ÷ 5.27	200	2900
THME 80	0,80	2.62	0,99	3.25	140	308	24÷32	5.27 ÷ 7.04	200	2900

* Attacco escluso - Linkage not included

UTENSILI DA TAGLIO - CUTTING FLAILS

Intercambiabili sullo stesso rotore Interchangeable on the same rotor	THME 60	THME 80			
	Nr. - No	Nr. - No	Ø cm	Ø in	
Coltelli snodati per: erba e cespugli Articulated "Y" flails for: grass, bushes		32	40	2	0,79



3500 ÷ 5500 Kg
7716 ÷ 12125 lb



30 ÷ 48 lt./min
6.59 ÷ 10.55 gal/min



Ø max 4 cm
Ø max 1.57 in

THLD

Construction

TESTATE TRINCIANTI IDRAULICHE PER MINIESCAVATORI
FLAIL HEADS FOR MINI-EXCAVATORS

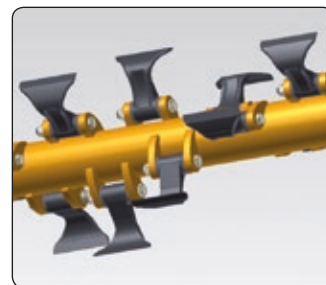

Dotazione standard

- Dispositivo autolivellante (escludibile, meccanicamente).
- Telaio con rinforzi interni ed esterni.
- Rotore elicoidale "Overlap".
- Valvola di massima ed anticavitazione.
- Tubi idraulici con raccorderia protetti da spirale - m 1,50 (esclusi innesti rapidi).
- Trasmissione diretta.
- Rullo di appoggio regolabile in altezza.
- Pattini antiusura sostituibili.
- Controtelaio interno.
- Protezioni in gommata antiabrasione.

Accessori

- Kit valvola regolatrice in acciaio tarata completa di tubi di collegamento motore per portate fino a 90 litri con prioritaria a 60 litri.
- Attacco a disegno con perni Ø mm 35/40/45.

Standard

- Self-levelling device (with mechanical lock).
- Frame with internal and external reinforcements.
- "Overlap" rotor.
- Anti-shock + anti-cavitation valve.
- Hydraulic pipes and connections protected by spiral - m 1,50 (quick couplings excluded).
- Direct drive.
- Rear adjustable roller.
- Replaceable wear skids.
- Double skin flail head.
- Front and rear abrasion resistant guard.

Accessories

- Calibrated steel adjusting valve Kit complete with pipes (for capacities up to 90 liters with 60 liters priority valve).
- Linkage as per drawing pins Ø mm 35/40/45.



INFORMAZIONI TECNICHE - TECHNICAL DATA

Modello Model										
	m	ft	m	ft	Kg*	lbs*	lt min÷max	Gal min÷max	max bar	max psi
THLD 85	0,85	2.79	1,08	3.54	170	374	30÷48	6.59÷10.55	200	2900
THLD 105	1,05	3.44	1,28	4.20	190	418	30÷48	6.59÷10.55	200	2900

* Attacco escluso - Linkage not included

UTENSILI DA TAGLIO - CUTTING FLAILS

Intercambiabili sullo stesso rotore Interchangeable on the same rotor		THLD 85	THLD 105		
		Nr. - No	Nr. - No	Ø cm	Ø in
Coltelli polivalenti e diritti per: erba, arbusti, cespugli, canne, legna Multiuse and straight blades for: grass, shrubs, bushes, sticks, wood.		24 + 12	32 + 16	3	1.18
Mazze stampate per: legna e arbusti Hammer blades for: wood, shrubs.		12	16	4	1.57

FERRI

SIMPLY. THE MOWER

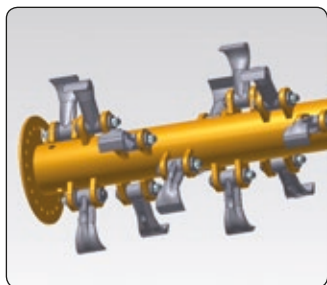
THM5500 ÷ 10000 Kg
12125 ÷ 22046 lb60 ÷ 100 lt./min
13.2 ÷ 22.0 gal/minØ max 8 cm
Ø max 3.15 in**TESTATE TRINCIANTI IDRAULICHE PER ESCAVATORI**
FLAIL HEADS FOR EXCAVATORS**Dotazione standard**

- Dispositivo autolivellante (escludibile meccanicamente).
- Telaio con rinforzi interni ed esterni.
- Rotore elicoidale "Overlap".
- Valvola di massima ed anticavitazione.
- Tubi idraulici con raccorderia protetti da spirale – m 1,80 (esclusi innesti rapidi).
- Trasmissione diretta.
- Rullo di appoggio regolabile in altezza.
- Pattini di usura sostituibili.
- Controtelaio interno.
- Protezioni in gommata antiabrasione.

Accessori

- Kit valvola regolatrice in acciaio tarata completa di tubi collegamento motore (per portate fino a 160 litri con prioritaria a 90 litri).
- Attacco a disegno con perni Ø mm 45/50.

Standard

- Self-levelling device (with mechanical lock).
- Frame with internal and external reinforcements.
- "Overlap" rotor.
- Anti-shock + anti-cavitation valve.
- Hydraulic hoses and fittings protected by spiral m 1,80 (excluding quick couplings).
- Direct drive.
- Rear adjustable roller.
- Replaceable wear skids.
- Double skin flail head.
- Front and rear abrasion resistant guard.

Accessories

- Calibrated steel adjusting valve Kit complete with pipes (for capacities up to 160 liters with 90 liters priority valve).
- Linkage as per drawing pins Ø mm 45/50.

**INFORMAZIONI TECNICHE - TECHNICAL DATA**

Modello Model										
	m	ft	m	ft	Kg*	lbs*	lt min÷max	Gal min÷max	max bar	max psi
THM 105	1,05	3.44	1,29	4.23	333	734	60÷100	13.2÷22.0	220	3190
THM 125	1,25	4.10	1,49	4.88	348	767	60÷100	13.2÷22.0	220	3190

* Attacco escluso - Linkage not included

UTENSILI DA TAGLIO - CUTTING FLAILS

Intercambiabili sullo stesso rotore Interchangeable on the same rotor		THM 105	THM 125		
		Nr. - No	Nr. - No	Ø cm	Ø in
Coltelli polivalenti per: erba, arbusti, cespugli, canne, legna Multiuse blades for grass, bushes, shrubs, sticks, wood		36	44	4	1.57
Mazze stampate per: legna e arbusti Hammer for wood and shrubs		18	22	6	2.36
Martelletti bidirezionali rotanti per legna Turning blades for wood		-	18	8	3.15



10000 ÷ 15000 Kg
22046 ÷ 33069 lb



90 ÷ 100 lt./min
19.8 ÷ 22.0 gal/min



Ø max 7 cm
Ø max 2.75 in

TIR

Construction

TESTATE TRINCIANTI IDRAULICHE PER ESCAVATORI
FLAIL HEADS FOR EXCAVATORS

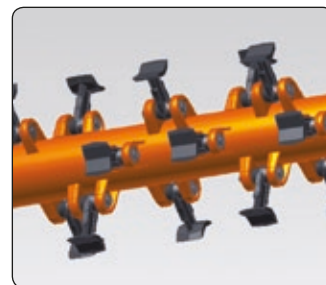

Dotazione standard

- Valvola di massima ed anticavitazione in linea.
- Tubi idraulici con raccorderia protetti da spirale - m 2,20 (esclusi innesti rapidi).
- Trasmissione a cinghie.
- Rullo di appoggio regolabile in altezza.
- Controtelaio interno.
- Pattini antiusura sostituibili.
- Protezione anteriore con catene.

Accessori

- Kit valvola regolatrice in acciaio tarata completa di tubi di collegamento motore per portate fino a 160 litri con prioritaria a 90 litri.
- Kit valvola regolatrice in acciaio tarata completa di tubi di collegamento motore per portate fino a 280 litri con prioritaria a 190 litri.
- Ralla di rotazione idraulica, 180°, per lavorare nei due sensi di marcia.
- Attacco a disegno con perni Ø mm 50/60.



INFORMAZIONI TECNICHE - TECHNICAL DATA

Modello Model					Kg*	lbs*				
	m	ft	m	ft			lt min÷max	Gal min÷max	max bar	max psi
TIR 150 Motore idraulico ad ingranaggi Gear Hydraulic system	1,45	4.75	1,68	5.51	630	1388	95÷110	19.8 ÷ 22.0	220	3190
TIR 150 Motore idraulico a pistoni Pyston Hydraulic system	1,45	4.75	1,68	5.51	630	1388	95÷110	19.8 ÷ 22.0	220	3190

(* con dispositivo autolivellante, attacco escluso - (*) With self-leveling kit, linkage not included

UTENSILI DA TAGLIO - CUTTING FLAILS

Intercambiabili sullo stesso rotore Interchangeable on the same rotor		TIR 150	
		Nr. - No	
Coltelli polivalenti e diritti per: erba, arbusti, cespugli, canne, legna Multiuse and straight flails for grass, bushes, shrubs, sticks, wood		48+24	5 / 1.97
Martelli bidirezionali per: legna e arbusti "T" Hammer for: wood		24	7 / 2.75

Standard

- In line anti-shock + anti-cavitation valve.
- Hydraulic pipes and connections protected by spiral - m 2,20 (quick couplings excluded).
- Belt transmission.
- Rear adjustable roller.
- Double skin flail head.
- Replaceable wear skids.
- Front guard with chains.

Accessories

- Calibrated steel adjusting valve kit for capacities up to 160 litres with 90 litres priority valve.
- Calibrated steel adjusting valve kit for capacities up to 280 litres with 190 litres priority valve.
- Hydraulic orientation gear, 180°, to work in both directions.
- Linkage as per drawing pins Ø mm 50/60.



Testata trinciante idraulica per lavori su terreni incolti, sottobosco e aree verdi, con erba, cespugli, sarmenti e rovi fino a Ø 4 cm.

Si applica a skid steer loaders e minipale con potenza compresa tra 55 HP e 100 HP e con portata d'olio da 55/12 a 95/21 lt/gal min.

Hydraulic flail head for works on uncultivated land, underwood and green areas, with grass, bushes, pruning and brambles up to Ø 4 cm.

It is applied to skid steer loaders with power ranging between 55 HP and 100 HP and with oil flow from 55/12 to 95/21 liters / gal min.

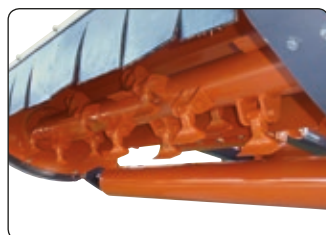

Rotore elicoidale "overlap".
"Overlap" rotor.



Valvola antiurto ed anti-cavitazione.
Anti-shock + anti-cavitation valve.



Autolivellante per seguire l'andamento del terreno con un'escursione di 185 mm.
Self levelling device to follow ground contours with 185 mm excursion.

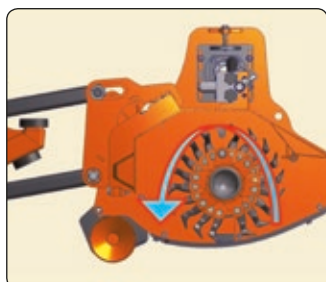

Scarico del materiale trinciato innanzi al rullo d'appoggio per garantire protezione del guidatore dal materiale trinciato e dalle polveri eventualmente sollevate.
The shredded material is discharged before the rear roller to ensure protection to the operator from debris and dust.

INFORMAZIONI TECNICHE - TECHNICAL DATA

Modello Model										
	m	ft	m	ft	Kg	lbs	lt min÷max	Gal min÷max	max bar	max psi
TSKID1600	1,60	5.25	1,87	6.13	712	1570	55÷70	12.1÷15.4	190÷210	2755÷3045
TSKID1800	1,80	5.90	2,07	6.79	748	1649	65÷80	14.3÷17.6	190÷210	2755÷3045
TSKID2000	2,00	6.56	2,27	7.44	780	1719	75÷95	16.5÷20.9	190÷210	2755÷3045

UTENSILI DA TAGLIO - CUTTING FLAILS

Intercambiabili sullo stesso rotore Interchangeable on the same rotor		TSKID 1600	TSKID 1800	TSKID 2000		
		Nr. - No	Nr. - No	Nr. - No	Ø cm	Ø in
Mazze stampate per: legna e arbusti Hammer for: wood and shrubs		16	18	20	4/5	1.57/1.97
Coltelli polivalenti per: erba, arbusti, cespugli, canne, legna Multiuse flails for: grass, bushes, shrubs, sticks, wood		48	54	60	3	1.18



Dotazione standard

- Attacco (SAE J2513) con dispositivo autolivellante.
- Spostamento meccanico (DX e SX cm 28).
- Rotore elicoidale "Overlap".
- Valvola di massima ed anticavitazione.
- Tubi idraulici con raccorderia protetti da spirale – m 3,00 (esclusi innesti rapidi).
- Trasmissione a cinghie.
- Slitte di appoggio regolabili in altezza con pattini antiusura sostituibili.
- Rullo di appoggio (Ø mm 168) regolabile in altezza.
- Controcoltello.
- Protezione in gommata antiabrasione.

Accessori

- Kit valvola regolatrice in acciaio completa di tubi collegamento motore (cod. TSK2007)
- Spostamento (DX e SX cm 28) a mezzo martinetto idraulico completo di tubi con raccorderia protetti da spirale (esclusi attacchi rapidi)
- Kit spostamento (DX e SX cm 28) a mezzo martinetto idraulico azionato da elettrovalvola completo di tubi con raccorderia, protetti da spirale (esclusi attacchi rapidi) (cod. TSK1602)

Standard equipment

- Linkage (SAE J2513) with self-levelling device.
- Mechanical side shift (RH and LH cm 28).
- Anti-shock + anticavitation valve.
- "Overlap" rotor.
- Hydraulic pipes and connections protected by spiral – m 3,00 (quick couplings excluded).
- Belts transmission.
- Adjustable skids with replaceable wear proof plates.
- Rear adjustable roller Ø 168 mm.
- Counterblade.
- Rubber and abrasion resistant guard.

Accessories:

- Steel adjusting valve Kit complete with pipes.
- 28 cm LH and RH hydraulic sideshift complete with hydraulic hoses and fittings protected by spiral (quick couplings excluded).
- Hydraulic side shift kit (28 cm LH and RH) engaged by electro valve, complete with hydraulic hoses and fittings protected by spiral (quick couplings not included) (cod. TSK1602)

**DECESPUGLIATRICE IDRAULICA PER TERNE E PALE ARTICOLATE.
HYDRAULIC FLAIL HEDGER MOWER FOR BACKHOE LOADERS AND
ARTICULATED LOADERS.**



Posizione in trasporto.
Transport position.

Comandi elettrici monoleva
Single lever electrical controls



La decespugliatrice idraulica serie TST50 offre un'ottima visibilità operativa essendo montata frontalmente alla trattrice.

The reach mower of the TST50 series provides ideal visibility by being front mounted on the tractor.



La particolare geometria dei bracci consente di posizionare la decespugliatrice in modo tale da non ostacolare la visibilità durante le fasi di trasferimento.
The particular geometry of the arms allows the reach mower positioning in such a way that it does not hinder the visibility during the transfer.



Sicurezza idraulica sul 2° braccio con accumulatore per il ritorno automatico (salvaguardia bracci in caso di ostacoli).
Hydraulic break-back with accumulator controlled autoreset facility.



Accumulatori di azoto.
Nitrogen accumulators.

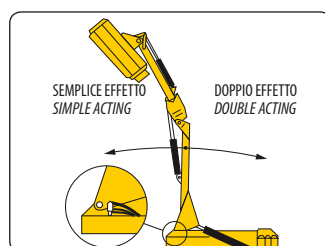

Dispositivo a doppio effetto.
Double acting device.

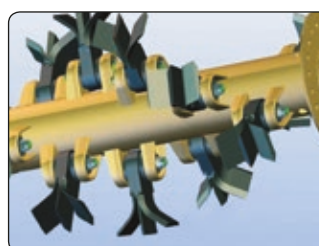

Rotore elicoidale "OVERLAP" a doppia elica con coltelli sovrapposti.
"OVERLAP" double row spiral rotor with overlapping flails.

INFORMAZIONI TECNICHE - TECHNICAL DATA

Modello Model														
	m	ft	m	ft	m	ft	m	ft	Kg	lbs	lt min÷max	Gal min÷max	max bar	max psi
TST 50	1,00	3.28	4,84	15.87	4,73	15.51	2,75	9.02	910	2006	80÷100	21.0÷26.0	220	3190



POSIZIONI DI LAVORO - WORKING POSITIONS

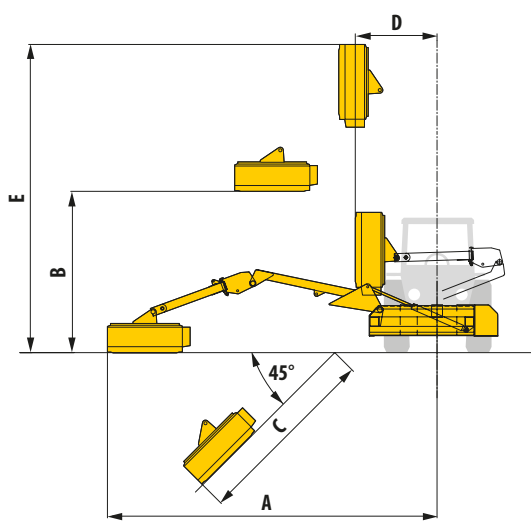

	TST50	
	m	ft
A	4,84	15.88
B	2,37	7.78
C	2,75	9.02
D	2,21	7.25
E	4,73	15.52

TESTATA TRINCIANTE - FLAILHEADS



Modello Model		
	Kg	lbs
TN 100	265	584

UTENSILI DA TAGLIO - CUTTING FLAILS

Intercambiabili sullo stesso rotore
Interchangeable on the same rotor

		TST 50 Nr. - No		
			Ø cm	Ø in
Coltelli polivalenti e dritti per: erba, arbusti, cespugli, canne, legna Multiuse and straight flails for grass, bushes, shrubs, sticks, wood		28+14	4	1.57
Martelli bidirezionali per: legna e arbusti "T" Hammer for: wood		14	5	1.96

Dotazione standard

- Testata trinciante TN100.
- Sistema "Floating" autolivellamento al terreno della testata trinciante.
- Sicurezza idraulica sul 2° braccio con accumulatore (salvaguardia in caso di ostacoli).
- Kit antiribaltamento bracci.
- Comandi elettrici progressivi con joystick.
- Sospensione del 1° braccio con accumulatore.
- Protezioni della testata in gommata antiabrasione.
- Zavorre di bilanciamento (Kg 135).

Accessori

- Scambiatore di calore con termostato (cod. TST500103)

Standard equipment

- Flail head mod. TN100.
- Floating head.
- Hydraulic break-back with accumulator controlled autoreset facility.
- Automatic kit for arms' overturn.
- Electric progressive controls with joystick.
- Lift float with accumulator.
- Front and rear abrasion resistant guard for flail head.
- Balancing ballast (Kg 135).

Accessories:

- Oil cooler with thermostat (cod. TST500103)



I dati tecnici riportati ed i modelli descritti si intendono non impegnativi. Per fini migliorativi il Costruttore si riserva il diritto di modifiche, senza preavviso.
Disegni e fotografie possono riferirsi a equipaggiamenti opzionali o ad allestimenti destinati ad altri Paesi. Per ogni altra informazione, rivolgersi alla nostra rete di vendita.
*The technical specifications indicated and models described are not binding. For the purpose of making improvements, the manufacturer reserves the right to make changes to them without prior notice.
Drawings and photographs may refer to optional equipment or configurations intended for other countries. If you require further information, please contact our sales network.*

FERRI[®]
SIMPLY. THE MOWER

FERRI srl - Via C. Govoni, 30 - 44034 TAMARA (Ferrara) Italy
Tel. + 39 0532.866 866 - Fax + 39 0532.866 851 - www.ferrisrl.it

