

Professional Line

ProTeam



FERRI®

Trinciatrici Laterali-Centrali
Central and offset mowers
Broyeurs et faucheuses d'accotements
Zentral- und seitlicher Mulcher
Trituradoras Laterales - Centradas

ZHE

PROFESSIONAL





La trinciatrice ZHE2500 risponde alle esigenze dei professionisti della manutenzione del verde, che richiedono alta produttività ed affidabilità nel tempo. La produttività è assicurata dalla importante larghezza di lavoro della macchina e dal rotore "OVERLAP" a doppia elica mentre l'affidabilità deriva dalla dotazione di importanti particolari costruttivi, quali il controtelaio interno a protezione integrale, l'ammortizzatore meccanico con molle, lo snodo di rotazione montato su boccole autolubrificanti, il rullo registrabile in altezza (Ø 168 mm con le calotte di estremità smontabili). Particolare attenzione è stata dedicata alla sicurezza in trasferimento, un doppio sistema idraulico di blocco impedisce l'involontario spostamento o inclinazione della trinciatrice.

The ZHE2500 Central and offset mower meets the needs of the professional green maintenance operators, who require high productivity and reliability. The productivity is ensured by the significant cutting width of the machine and by the "Overlap" double helix rotor. The reliability stems from the presence of relevant structural details, such as the inner subframe all round protection, the shock absorber with mechanical springs, the rotation joint mounted on self-lubricating bushings and the height adjustable roller (Ø 168 mm with removable end caps). Particular attention has been paid to the safety during transportation, a double hydraulic lock system prevents unintentional movement or the oscillation of the mower.

Le broyeur ZHE2500 répond aux besoins d'entretien professionnel qui demande une forte productivité et fiabilité. La productivité est assurée par l'importante largeur de travail de la machine et par le rotor « OVERLAP » à double hélice tandis que la fiabilité provient de détails

structurels tels que la tôle de blindage, l'amortisseur mécanique à ressorts, la biellette pivotante sur axe bague et lubrifié, le rouleau d'appui réglable en hauteur (Ø 168 mm avec embouts amovibles). Une attention particulière a été accordée à la sécurité lors de transport : un double blocage hydraulique empêche l'inclinaison involontaire du broyeur.

Das neue Mulchgerät ZHE2500 ist auf die Ansprüchen der Profis in der Landschaftspflege und Landwirtschaft abgestimmt und steht für hohe Produktivität und kontinuierliche Zuverlässigkeit. Für die Produktivität steht die große Arbeitsbreite von 2,50m und der Rotor "Overlap" mit doppelten Spiralen. Die hohe Zuverlässigkeit wird durch die komplette serienmäßigen Ausstattung, das doppelwandige Gehäuse, den mechanischen Springstoßdämpfer, die höhenverstellbare Stützwalze und dem Drehgelenk mit selbstschmierenden Buchsen gewährleistet. Besondere Aufmerksamkeit wurde auf die Transportsicherung gelegt, wobei durch ein doppeltes hydraulisches Sperrsystem die ungewollte Bewegung und Neigung der Maschine verhindert wird.

La trituradora ZHE2500 responde a las exigencias de los profesionales del mantenimiento de las áreas verdes, que solicitan alta productividad y fiabilidad en el tiempo. La productividad está asegurada por la importante anchura de la máquina y del rotor "OVERLAP" de doble hélice mientras la fiabilidad deriva de la composición de importantes componentes constructivos, como el contra chasis interno con protección integral, amortiguador mecánico con muelles, la articulación de rotación montada sobre casquillos auto lubricados, el rulo graduable en altura (Ø 168mm con las tapas de los extremos desmontables). Particular atención ha sido la dedicada a la seguridad en los desplazamientos, un doble sistema hidráulico de bloqueo impide el involuntario desplazamiento o inclinación de la trituradora.

Trinciatrici Laterali-Centrali Central and offset mowers Broyeurs et faucheuses d'accotements Zentral- und seitlicher Mulcher Trituradoras Laterales - Centradas



SAFETY

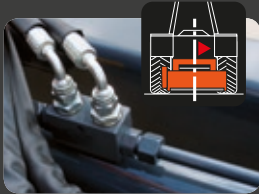

- Valvola di blocco idraulico in trasporto, inserimento automatico (no catene, no staffe).
- Hydraulic block valve for transport with automatic activation (no chains or holders).
- Soupape de blocage hydraulique pendant le transport, insertion automatique (sans chaînes ou supports).
- Hydraulisches Sperrventil mit automatischer Betätigung im Transportfall (keine Ketten oder Bügel)
- Válvula para el bloqueo hidráulico en transporte con dispositivo automático de entrada (ni cadenas, ni soportes).



- Rubinetto per il blocco idraulico in trasporto, inserimento manuale (no catene, no staffe).
- Hydraulic block tap for transport with manual activation (no chains or holders).
- Robinet pour le blocage hydraulique pendant le transport, insertion manuel (sans chaînes ou supports).
- Hydraulischer Sperrhahn mit Handbetätigung im Transportfall (keine Ketten oder Bügel).
- Grifo para el bloqueo hidráulico en el transporte con dispositivo manual de entrada (no cadenas, ni soportes)

RELIABILITY



- Slitte di appoggio tubolari con pattini anti usura sostituibili.
- Wear resistant and replaceable tubular skids.
- Patins d'usure tubulaires et remplaçables.
- Verschleißfeste und austauschbare Rohrkufen.
- Patines tubulares antidesgaste reemplazables.

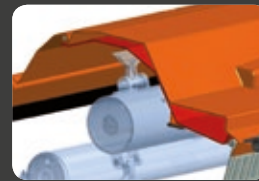

- Controtelaio interno a protezione integrale del corpo trinciante.
- Inner lining for a complete protection of the frame.
- Tôle de blindage interne pour protéger intégralement du châssis.
- Doppelwandiges Gehäuse.
- Coraza reforzada para una protección completa de la estructura.



- Ammortizzatore meccanico a molle. Salvaguardia in caso di ostacolo.
- Shock absorber with mechanical springs.
- Amortisseur mécanique à ressorts.
- Mechanischen Springstoßdämpfer.
- Amortiguador mecánico con muelles.

FERRI®



ZHE 2500

PERFORMANCE



- Gruppo moltiplicatore esterno alla trasmissione.
- Gearbox is fitted outside the transmission cover.
- Boîtier multiplicateur à l'extérieur de la transmission.
- Getriebe außerhalb der Übertragungsgruppe.
- Grupo reductor externo a la transmisión.



- Rotore "OVERLAP" a doppia elica per mazze e coltelli polivalenti.
- "OVERLAP" spiral rotor with two spiral rows for either hammer blades and multiuse flails.
- Rotor « OVERLAP » hélicoïdal en spirale double opposés pour équipement avec marteaux et coupeaux.
- Spiralrotor "OVERLAP" mit zwei Spiralen für Schlägel und Mehrzweckmesser.
- Rotor helicoidal "OVERLAP" con rotor con cuchillas multiuso o martillos.



- Rullo registrabile in altezza Ø 168 mm con le calotte di estremità smontabili.
- Height adjustable roller Ø 168 mm with removable end caps.
- Rouleau d'appui réglable en hauteur Ø 168 mm avec embouts amovibles.
- Höhenverstellbare Stützwalze mit abnehmbaren Endkappen.
- Rulo graduable en altura Ø 168 mm con las tapas de los extremos desmontables.

TECHNICAL

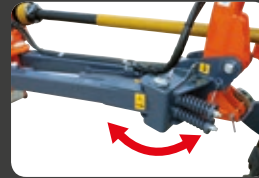

- Telaio oscillante. Autolivellamento al terreno.
- Floating frame following the ground contours.
- Attelage oscillant permettant le suivi du dénivellement du terrain.
- Gelenkiger Rahmen (Bodenanpassung).
- Coraza basculante (el cabezal se adapta a las ondulaciones del terreno).



- Snodo di rotazione montato su boccole autolubrificanti.
- Rotation joint on self lubricating bushing.
- Axe pivotant monté sur bagues autolubrifiées.
- Drehgelenk mit selbstschmierenden Buchsen.
- Nudos de rotación y brazo paralelogramo lubricados.





Trinciatrici Laterali-Centrali
Central and offset mowers
Broyeurs et faucheuses d'accotements
Zentral- und seitlicher Mulcher
Trituradoras Laterales - Centradas



Informazioni tecniche	Technical data	Caractéristiques techniques	Technische Angaben	Informaciones técnicas	ZHE Professional
Modello	Model	Modèle	Modell	Modelo	2500
Larghezza di lavoro	Width of cut	Largeur de travail	Arbeitsbreite	Ancho de corte	m 2,50
Estensione massima laterale*	Max Sidesliding*	Extension max.*	Max seitliche Reichweite*	Máx desplazamiento lateral*	m 3,67
Inclinazione testata	Head angle movement	Angle de travail	Neigung Mulcher	Angulo de giro del cabezal	60°/90°
Peso	Weight	Poids	Gewicht	Peso	Kg 1360
Trattrici	Tractor	Tracteurs	Schlepper	Tractor	HP/PS 100/160
Peso minimo trattrice	Min. Tractor weight	Poids mini	Schleppermindestgewicht	Peso mínimo tractor	Kg 5000
Larghezza minima trattrice	Min. Tractor width	Largeur mini	Schleppermindestbreite	Ancho mínimo tractor	m 2,30
Presa di forza	Pto	Prise de force	Zapfwelle	T.d.f.	Rpm/UpM 540
Velocità periferica	Blade tip speed	Vitesse périphérique	Messer Geschwindigkeit	Velocidad de cuchilla	m/sec 52

* Dall'asse della trattrice all'estremità della testata trinciante - Reach measured from tractor centre line to head edge - Du centre du tracteur à l'extrémité du groupe
 Von der Mitte des Schleppers bis Außenkante des Mulchers - Centro desde el tractor al extremo del cabezal

Utensili di taglio / Flails / Marteaux / Martillos / Messertyp			
Intercambiabili sul rotore "OVERLAP" Interchangeable on the same rotor ("OVERLAP") Interchangeables sur le même rotor ("OVERLAP") Intercambiables en el mismo rotor ("OVERLAP") Auf selbem Rotor auswechselbar ("OVERLAP")			
Mazze stampate per: legna, erba, sarmenti Forged hammer-blades for: woods, twigs, grass Marteaux forgés pour bois, sarments, herbe Martillos forjados para: madera, poda, hierba Schlägel für: Holz, Rebholz, Gras	Ø max 5 cm		N° 26
Coltelli polivalenti per: erba, arbusti, cespugli, canne Multiuse flails for: grass, bushes, shrubs, sticks, wood Couteaux polyvalents pour herbe, buissons, arbustes, canaux Cuchillas multiuso para: hierba, arbustos, poda, madera Mehrzweckmesser für: Gras, Gebüsch, Sträucher	Ø max 4 cm		N° 78

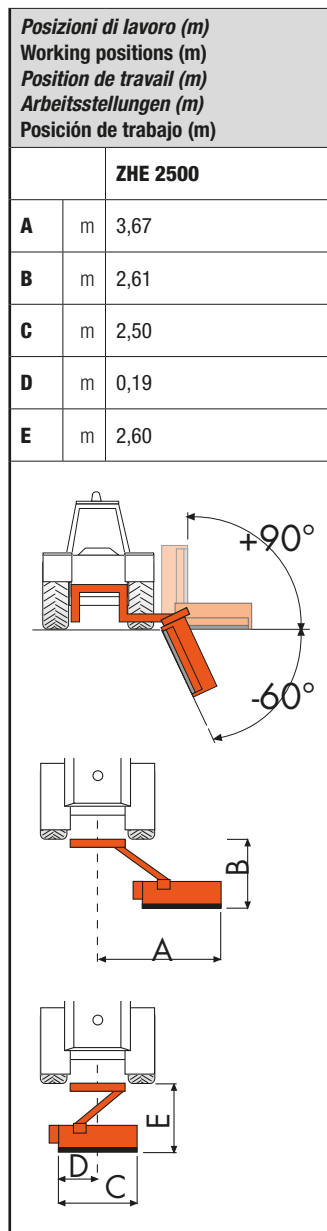

campbelladv.com 56114 - ZHE Professional IT/VE/DE Rev.0 - 11/14 - 1500 - Dall'indicativo e non impegnativi. All data subject to change. Documentation et photos non contractuelles. Sämtliche Angaben nur richtungsweise und unverbindlich. Todos los datos son orientativos y están sujetos a cambio sin previo aviso.



FERRI srl
 Via Govoni, 30
 44034 Tamara (FE) Italy
 Tel. +39 0532 866866
 Fax +39 0532 866851
 info@ferrisrl.it - www.ferrisrl.it

